

Z5394
Rigging manual 1.2 en

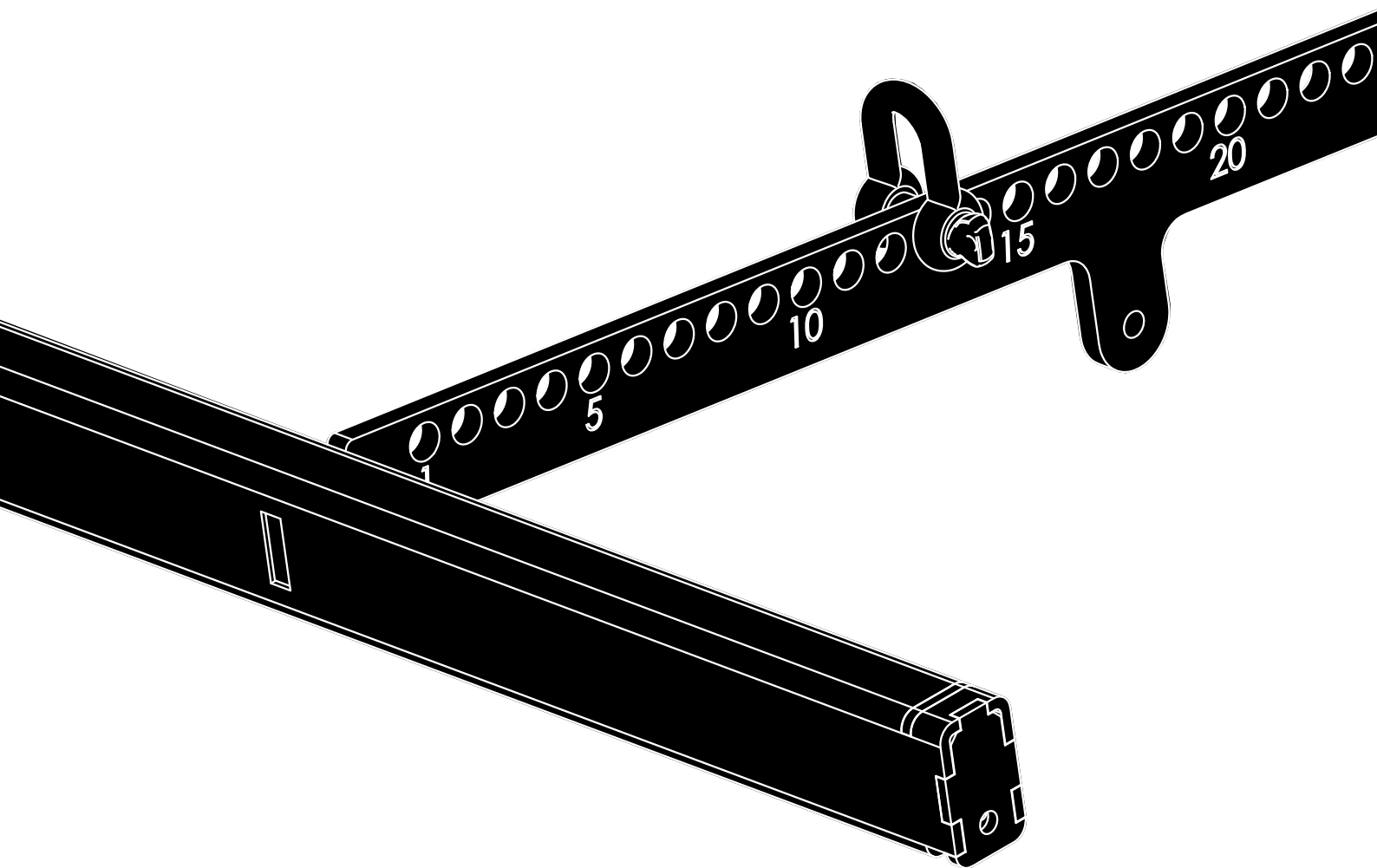

General information

Z5394 Rigging manual

Version: 1.2 en, 03/2021, D2719.EN .01

Copyright © 2021 by d&b audiotechnik GmbH & Co. KG; all rights reserved.

Keep this document with the product or in a safe place so that it is available for future reference.

We recommend you to regularly check the d&b website for the latest version of this document.

When reselling this product, hand over this document to the new owner.

If you supply d&b products, please draw the attention of your customers to this document. Enclose the relevant documents with the systems. If you require additional documents for this purpose, you can order them from d&b.

d&b audiotechnik GmbH & Co. KG
Eugen-Adolff-Str. 134, D-71522 Backnang, Germany
T +49-7191-9669-0, F +49-7191-95 00 00
docadmin@dbaudio.com, www.dbaudio.com

1	Z5394 Y Flying adapter	4
1.1	Safety	4
1.1.1	Intended use	4
1.1.2	General safety	4
1.1.3	Load safety information	4
1.2	Scope of supply	4
2	Assembly	5
2.1	Suspension options	5
2.2	Preparing the setup	5
2.3	Order of assembly	6
2.4	Hoisting and securing the array (secondary safety)	8
3	Care and maintenance	9
3.1	Transport / Storing	9
3.2	Visual and functional inspection	9
4	Manufacturer's declaration	10
4.1	EU conformity (CE symbol)	10
4.2	Disposal	10

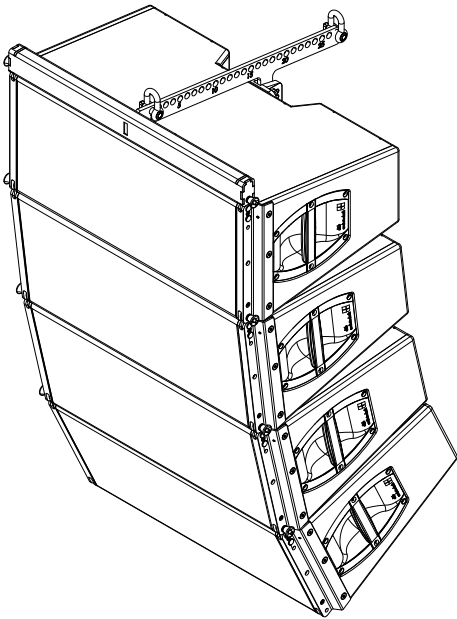

1.1 Safety

1.1.1 Intended use

The Z5394 Y Flying adapter must only be used in conjunction with the d&b Y-Series Y8 and Y12 loudspeakers as described in this manual.

1.1.2 General safety

- Installation and setup should only be carried out by qualified and authorized personnel observing the valid national Rules for the Prevention of Accidents (RPA).
- It is the responsibility of the person installing the assembly to ensure that the suspension/fixing points are suitable for the intended use.
- Always carry out a visual and functional inspection of the items before use. In case there is any doubt as to the proper functioning and safety of the items, these must be withdrawn from use immediately.

Please also refer to ⇒ Chapter 3 "Care and maintenance" on page 9.

1.1.3 Load safety information

NOTICE!

The Z5394 Y Flying adapter is designed to suspend a total of 6 x Y8 or Y12 cabinets which corresponds to a total system weight of 123 kg (271 lb) – SWL.

1.2 Scope of supply

Please verify the shipment for completeness and proper condition of the items.

Qty.	d&b Code	Description
1	Z5394	d&b Y Flying adapter [1]
Including:		
1	E6507	1t shackle [2]
1	D2719.EN .01	Z5394 Rigging manual

Weight 3.6 kg / 8 lb

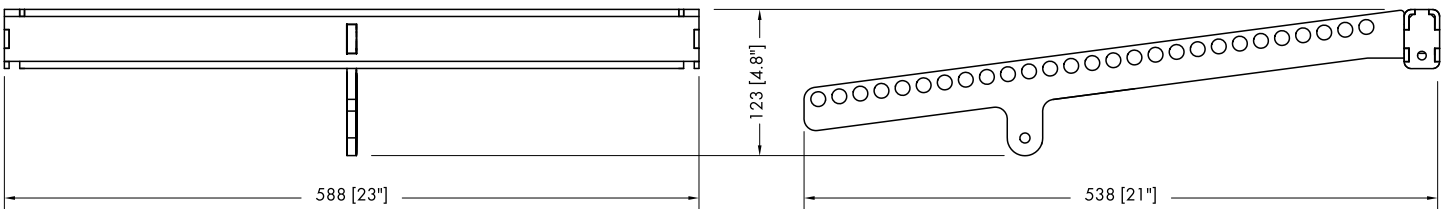
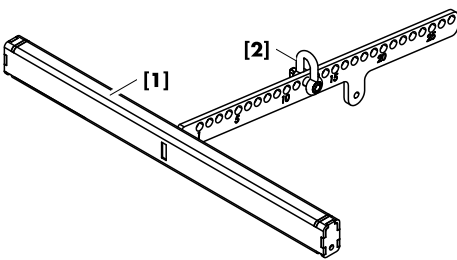

Z5394 Y Flying adapter dimensions in mm [inch]

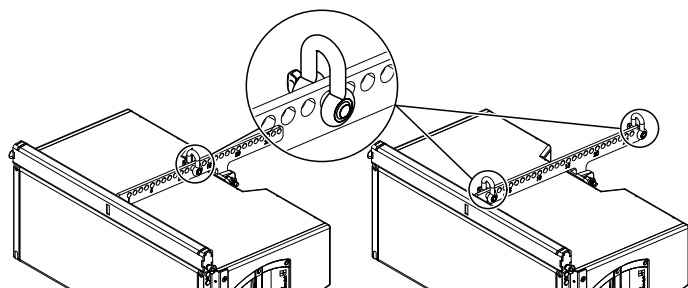
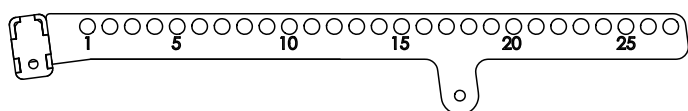

Y Flying adapter pickpt. 10.0 (18.9 cm)

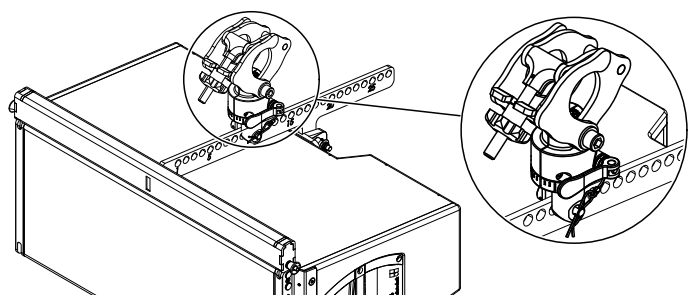

2.1 Suspension options

The center bar of the adapter is equipped with a total of 27 holes to allow the suspension of the array and the setting of different vertical angles.

The holes are numbered with an increment of five.

Single or dual pick point operation

The array can be suspended using one or two E6507 1t shackle(s) and appropriate lifting devices or steel wire ropes.

With "Dual pick point operation", the vertical aiming of the entire array is set by trimming the respective lifting devices.

With "Single pickpoint operation", the overall vertical aiming of the entire array is defined by using a particular hole of the hole index of the center bar.

The corresponding hole position is calculated using the d&b ArrayCalc simulation software. For this purpose, ArrayCalc can be downloaded at www.dbaudio.com.

Note: Please note that you have to check the «Rigging plot» page within ArrayCalc, as the «Sources» page only indicates hole numbers for the Z5390Y Flying frame, but not for the Z5394 Y Flying adapter.

The use of ArrayCalc is described in "TI 385 d&b Line array design, ArrayCalc" which is included in the ArrayCalc software. The TI can also be downloaded at www.dbaudio.com.

In ArrayCalc, the closest pickpoint hole and the exact distance in cm/inch are displayed in the «Main» array section ⇒ «Pickpoints and load» (last entry) on the «Rigging plot» page, provided the corresponding array is selected on this page.

Z5147 Rota clamp option

Alternatively, the array can be suspended and horizontally aligned from a single pickpoint using the d&b Z5147 Rota clamp. The clamp allows the load to be attached to overhead bars or truss with a tube diameter of up to 50 mm (2").

Attachment

Choose the appropriate hole position in the center bar according to the ArrayCalc calculation and attach the Rota clamp correspondingly.

Note: Please observe the relevant mounting instructions which are enclosed with the Rota clamp.

2.2 Preparing the setup

General

Check the acoustical and mechanical setup using ArrayCalc and prepare enough printouts for each array.

The plan enables the riggers to set up the suspension points, the securing points and the chain hoists.

When on site first:

- Clear the working areas and ensure there is enough space to set up and lift the array.
- Check that the hoists are exactly in the specified position.
- Ensure the chains are not twisted.
- Prepare the cables and link cables according to the number of amplifier channels and cabinets used.

Inspections before setup

Before setting up the array, carry out a visual inspection of all system components for faults. This also includes the loudspeakers and in particular the rigging parts of the cabinets (Front and Splay/Rear links).

Damaged components must be withdrawn from use immediately.

Please follow the instructions given in ⇒ Chapter 3 "Care and maintenance" on page 9.

2.3 Order of assembly

Due to the compact size of the Y-Series TOP cabinets and the maximum number of six cabinets that can be flown, the assembly may be carried out either suspended or on the ground. The following description refers to the suspended assembly.

1. Prepare the first cabinet

1. At the front release the Locking pins of the Front links.
⇒ The Front links will slide out automatically.
2. On the rear release both Locking pins and fold out the Splay link.

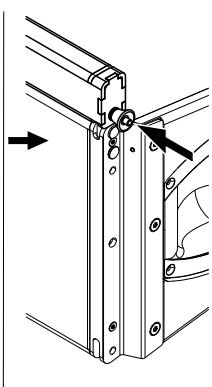
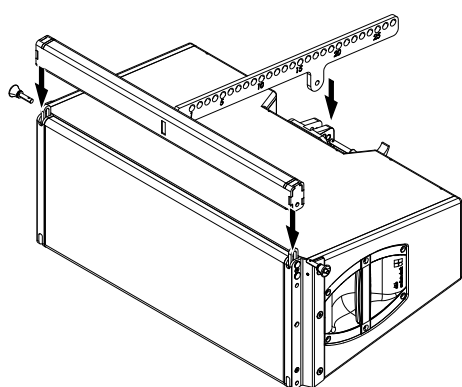
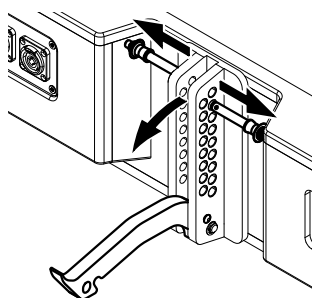
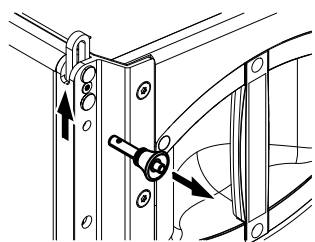

2. Attach the Flying adapter

1. Attach the Flying adapter on top of the cabinet until the Front links of the cabinet fit into the slots at the front of the adapter.
2. Insert and lock the Locking pins of the cabinet's Front links on both sides.

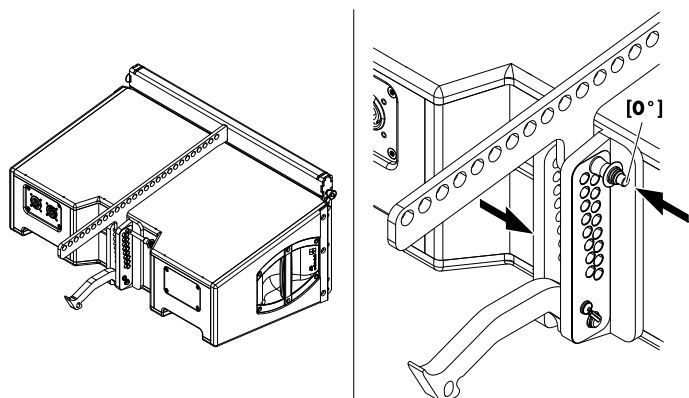

3. On the rear align the Flying adapter with the **[0°]** hole of the rear rigging strand.
4. Insert and lock one Locking pin in the **[0°]** hole.

Note: The second Locking pin is not needed and can be stored in one of the remaining holes.

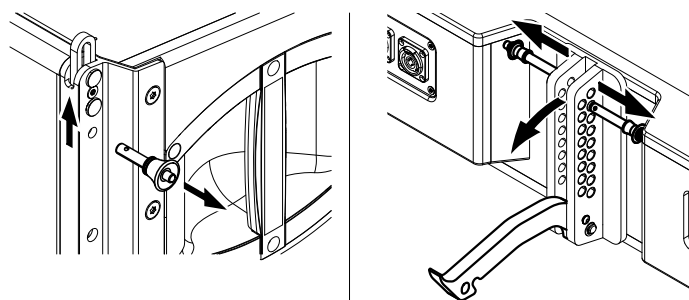

3. Prepare the next cabinet

1. Prepare the Front and Splay links of the next cabinet.

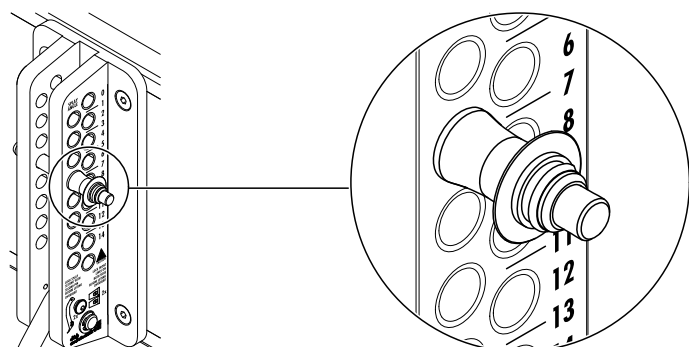

4. Preset the splay angle

The splay angles between adjacent cabinets are set at the central rear rigging strands of the cabinets and can be set in the range from 0° to 14° in 1° steps.

Preselect the splay angle according to your ArrayCalc simulation and insert and lock one Locking pin in the appropriate hole.

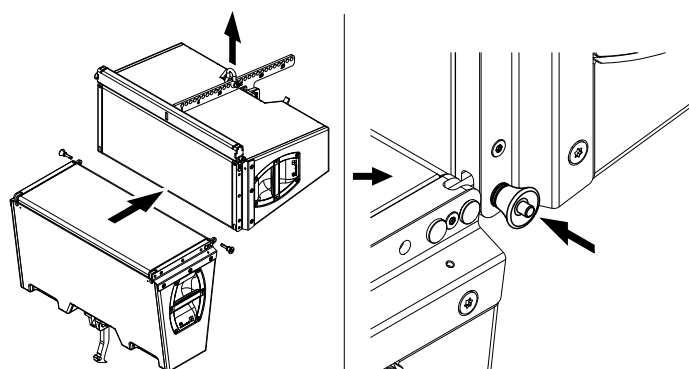

5. Attach the next cabinet

1. Suspend the assembly according to the desired suspension option.
2. Lift the assembly to a suitable working height.
3. Attach the prepared cabinet to the corresponding slots on the front of the upper cabinet.
4. Insert and lock the Locking pins of the cabinet's Front links on both sides.

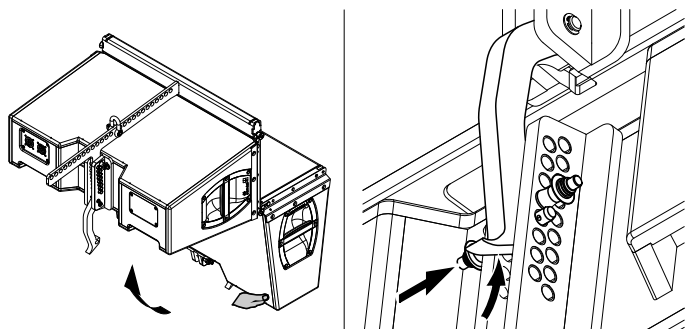

5. Raise the bottom cabinet until the hook of the Splay link of the upper cabinet has hooked into the preset Locking pin.
6. Release the cabinet and insert the second Locking pin (Safety pin) to secure the Splay link.

To add further cabinets, proceed in the same manner until the assembly is completed.

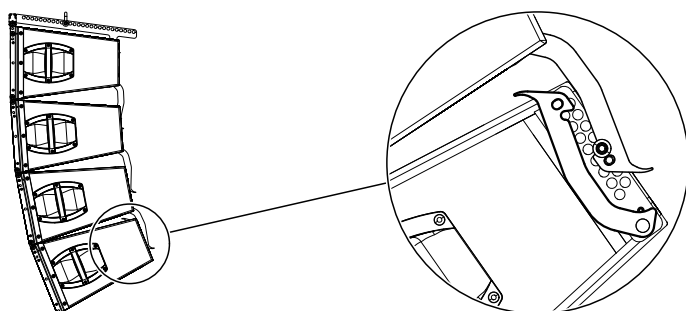

6. Splay link of the last cabinet

The Splay link of the last cabinet can be kept in its park position.

Note: In this case, the lowest cabinet can be set to the following splay angles: 3°, 5° and 7° to 14°.

7. Rig the cabling

Connect the flying cables and link cables according to the number of amplifier channels and cabinets used.

8. Check the assembly

Before hoisting the array to its operating position recheck the actual status of the entire assembly.

- Check the attachment of the shackles or Rota clamp to the Flying adapter.
- Check the attachment of the Flying adapter to the first cabinet and ensure all Locking pins are properly inserted and locked.
- Check all Front links on both sides of the cabinets and ensure all Locking pins are properly inserted and locked.
- Check the splay angle settings and the Splay links on the rear of the cabinets and ensure all Locking pins are properly inserted and locked.
- In "Single pick point operation" check the desired total vertical aiming of the entire array using an inclinometer.

2.4 Hoisting and securing the array (secondary safety)

When all the mechanical adjustments, system checks and safety checks have been made, the array can be hoisted up to its operating position.

When hoisting the array, ensure that the loudspeaker cables do not get caught anywhere. The cables can be strapped together with the motor cable to form a loom while the system is hoisted.

The chain hoist motors must raise the system slowly and evenly so that it does not swing or move from side to side during hoisting.

When the array is in its final operating position the **secondary safety** must be applied.

3.1 Transport / Storing

During transport ensure the rigging components are not stressed or damaged by mechanical forces. Use suitable transport cases.

Due to their surface treatment the rigging components are temporarily protected against moisture. However, ensure the components are in a dry state while stored or during transport and use.

3.2 Visual and functional inspection



WARNING!

Potential risk of personal injury and/or damage to material

To eliminate the potential risk of accident due to malfunctioning of a component, regularly inspect all system components.

Cabinet enclosure

- Visual inspection of all fitting plates for obvious damage (e.g. cracks or corrosion).
- Visual inspection of the rear rigging strand for obvious damage (e.g. cracks, deformation or corrosion) including all drilled holes of the component.
- Inspection of all fitting plates including front grills to ensure they are securely attached.
- Regularly lubricate the sockets using WD-40® or a similar product.

Front and Splay links

Visual inspection regarding deformation and damage (e.g. cracks and corrosion) including all drilled holes of the component.

Locking pins

- Visual inspection for deformation, cracks and corrosion of the component.
- Inspection for missing ball bearings and damage.
- Functional inspection of the release mechanism to ensure it operates properly.
- Regularly lubricate the Locking pins using WD-40® or a similar product.

Z5394 Y Flying adapter

Visual inspection regarding deformation and damage (e.g. cracks and corrosion) including all drilled holes of the component.



4.1 EU conformity (CE symbol)

This declaration applies to:

d&b Z5394 Y Flying adapter

manufactured by d&b audiotechnik GmbH & Co. KG.

All product variants are included, provided they correspond to the original technical version and have not been subject to any later design or electromechanical modifications.

We herewith declare that said products are in conformity with the provisions of the respective EC directives including all applicable amendments.

A detailed declaration is available on request and can be ordered from d&b or downloaded from the d&b website at www.dbaudio.com.

4.2 Disposal

When out of use the rigging components must be disposed of in accordance with the national environmental regulations.

Ensure that damaged rigging components are disposed of in a way that they cannot be used again.

